

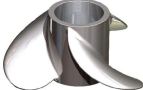









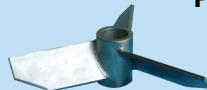

Lambda Agitator Impellers

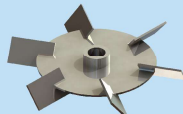
<p>P1</p> 	<p>Marine Propeller</p> <p>For mixing low viscous liquid (less than 100 cPS) Example : mixing of syrup in fruit juice</p>	<p>A1</p> 	<p>Pitch-blade Turbine</p> <p>For rapid submergence of floating particulate solids (less than 10,000 cPs) Example : dispersion of gas droplet in polymerization</p>
<p>P2</p> 	<p>Standard Propeller</p> <p>For mixing low viscous liquid (less than 100 cPS) Example : preparation of acid and alkali solutions in chemical industries</p>	<p>A2</p> 	<p>Pitch-blade Turbine</p> <p>For rapid submergence of floating particulate solids (less than 10,000 cPs) Example : dispersion of gas droplet in polymerization</p>
<p>P3</p> 	<p>Stretched Propeller</p> <p>For mixing low viscous liquid (less than 100 cPS)</p>	<p>T1</p> 	<p>Flat-blade Disc Turbine</p> <p>For high shear gas-liquid dispersion (less than 15,000 cPs) Example : dispersion of air bubbles in fermenter dispersion of air bubbles in fermentor.</p>
<p>P4</p> 	<p>Constant-pitched Propeller (Hydro foil)</p> <p>For mixing low viscous liquid (less than 100 cPs) with high flow rate at very low shear</p>	<p>T2</p> 	<p>Flat-blade Disc Turbine</p> <p>For high shear gas-liquid dispersion (less than 15,000 cPs) Example : dispersion of air bubbles in fermenter dispersion of air bubbles in fermentor.</p>
<p>D1</p> 	<p>Saw-toothed Disc Turbine (High-shear dispersing)</p> <p>For dispersion of solid particles in liquid phase Example : dispersion of pigment in paint industries</p>	<p>T3</p> 	<p>Curve-blade Turbine</p> <p>For aiding solid settlement</p>
<p>C1</p> 	<p>Anchor</p> <p>For blending and heat transfer of high viscous liquid (5,000 - 50,000 cPs) Example : mixing of grinded cassava in hydrolysis tank</p>	<p>T4</p> 	<p>Flat-blade Turbine</p> <p>For high shear gas-liquid dispersion and emulsion mixing (less than 50,000 cPs.). This impeller can be used for blending applications when high torque agitation is required. Example : mixing chemicals in wastewater treatment plants</p>
<p>S1</p> 	<p>Double Spiral</p> <p>For blending of slurry and solid particles less than 1,000,000 cPs Example : blending of chilli paste in food industries</p>	<p>T5</p> 	<p>Bar Disc Turbine</p> <p>For very high shear solid liquid dispersion (less than 50,000 cPs) Example : production of adhesive emulsion</p>
<p>R1</p> 	<p>Double Ribbon</p> <p>For mixing free flowing ingredients for fine powder including plastics, chemicals, coloring and mixing feed for agriculture</p>		

Agitator Shaft (Type : S-3) Solid Shaft

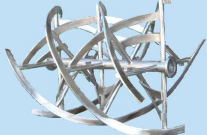
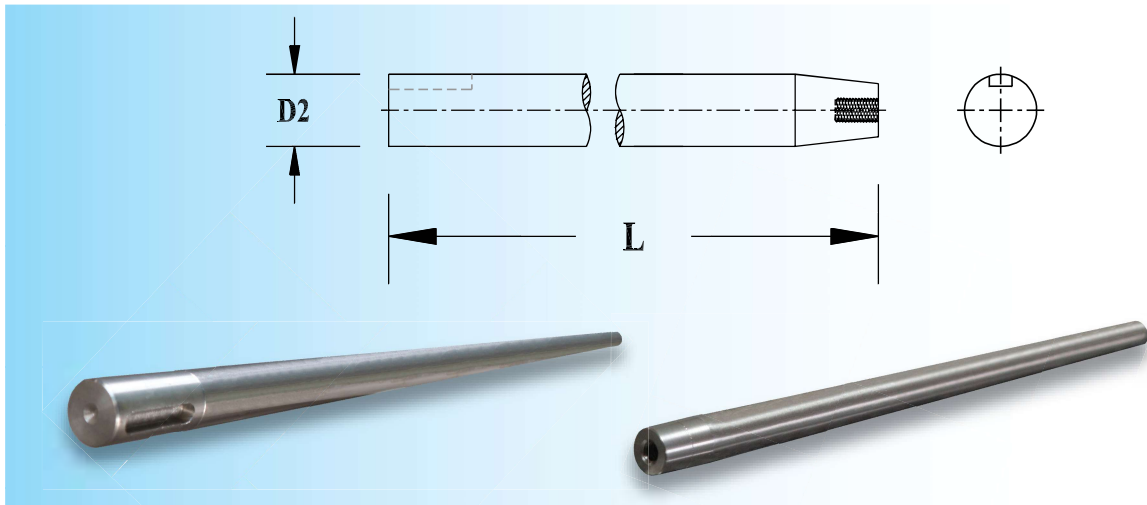

Approx. Dimension (mm)		Part Number	Approx. Total Weight (kg)
D2	L		
12	250	S3x012A-R0250	0.23
	300	S3x012A-R0300	0.28
	350	S3x012A-R0350	0.32
	400	S3x012A-R0400	0.37
	450	S3x012A-R0450	0.41
	500	S3x012A-R0500	0.46
16	250	S3x016A-R0250	0.41
	300	S3x016A-R0300	0.49
	350	S3x016A-R0350	0.57
	400	S3x016A-R0400	0.65
	450	S3x016A-R0450	0.73
	500	S3x016A-R0500	0.81
19	450	S3x019A-R0450	1.03
	500	S3x019A-R0500	1.14
	550	S3x019A-R0550	1.25
	600	S3x019A-R0600	1.37
	650	S3x019A-R0650	1.48
	750	S3x019A-R0750	1.71
25	500	S3x025A-R0500	1.97
	550	S3x025A-R0550	2.16
	600	S3x025A-R0600	2.36
	650	S3x025A-R0650	2.56
	750	S3x025A-R0750	2.95
	950	S3x025A-R0950	3.74
	1,000	S3x025A-R1000	3.93
	1,100	S3x025A-R1100	4.32
	1,250	S3x025A-R1250	4.91
32	750	S3x032A-R0750	4.83
	800	S3x032A-R0800	5.15
	900	S3x032A-R0900	5.80
	950	S3x032A-R0950	6.12
	1,000	S3x032A-R1000	6.44
	1,100	S3x032A-R1100	7.08
	1,250	S3x032A-R1250	8.05
	1,350	S3x032A-R1350	8.69
	1,500	S3x032A-R1500	9.66

Agitator Coupling

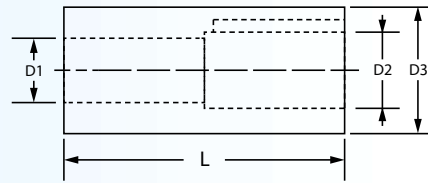
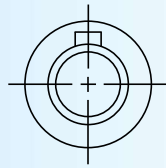

Type : C-1

SUS 304

SUS 316

Approx. Dimension (mm.)				Part Number	Part Number
D1	D2	D3	L		
11	12	20	46	C1T011A-xxx04	C1U011A-xxx04
14	16	25	60	C1T014A-xxx05	C1U014A-xxx05
19	19	32	80	C1T019A-xxx06	C1U019A-xxx06
20	19	32	80	C1T020A-xxx08	C1U020A-xxx08
24	25	38	100	C1T024A-xxx08	C1U024A-xxx08
25	25	38	100	C1T025A-xxx08	C1U025A-xxx08
28	25	44	120	C1T028A-xxx08	C1U028A-xxx08
30	32	44	120	C1T030A-xxx08	C1U030A-xxx08
35	35	50	140	C1T035A-xxx10	C1U035A-xxx10
38	38	55	160	C1T038A-xxx10	C1U038A-xxx10
40	38	55	160	C1T040A-xxx12	C1U040A-xxx12
42	44	60	180	C1T042A-xxx12	C1U042A-xxx12
45	44	60	180	C1T045A-xxx14	C1U045A-xxx14
48	50	75	200	C1T048A-xxx14	C1U048A-xxx14
50	57	75	200	C1T050A-xxx14	C1U050A-xxx14
60	63	80	240	C1T060A-xxx18	C1U060A-xxx18
70	69	90	280	C1T070A-xxx20	C1U070A-xxx20
80	76	110	320	C1T080A-xxx22	C1U080A-xxx22
90	89	120	360	C1T090A-xxx25	C1U090A-xxx25

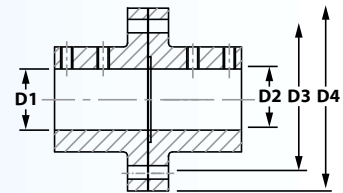
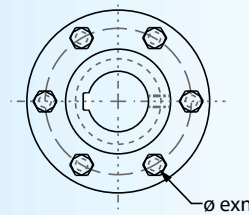

Type : C-4

SUS 304

SUS 316

Approx. Dimension (mm.)							Part Number	Part Number
D1	D2	D3	D4	L	øe	n		
20	19	60	80	80	9	4	C4T020A-xxx06	C4U020A-xxx06
25	25	67	90	100	11	4	C4T025A-xxx08	C4U025A-xxx08
30	32	72	95	120	11	4	C4T030A-xxx08	C4U030A-xxx08
35	35	82	105	140	11	4	C4T035A-xxx10	C4U035A-xxx10
40	38	87	110	160	11	6	C4T040A-xxx12	C4U040A-xxx12
45	44	92	115	180	11	6	C4T045A-xxx14	C4U045A-xxx14
50	57	97	120	200	11	6	C4T050A-xxx14	C4U050A-xxx14
60	63	115	140	240	13	6	C4T060A-xxx18	C4U060A-xxx18
70	69	125	150	280	13	6	C4T070A-xxx20	C4U070A-xxx20
80	76	140	165	340	13	6	C4T080A-xxx22	C4U080A-xxx22
90	89	150	175	340	13	8	C4T090A-xxx25	C4U090A-xxx25
100	100	160	185	420	13	8	C4T100A-xxx25	C4U100A-xxx25
110	100	170	195	420	13	8	C4T110A-xxx28	C4U110A-xxx28
120	100	185	210	420	13	8	C4T120A-xxx32	C4U120A-xxx32

Agitator Accessories

1. Direct Drive Motor

Special design for agitator

Part Number	Description								
	Motor				Shaft Dia. (mm.) D1	Flange Dimension (mm.)			
	Power Supply	Hp	kW	Speed (rpm)		D4	D5	øe	n
MGS005B-D1500	1 Ph/ 220V./ 50Hz IP55, 4 Pole	0.50	0.37	1,500	19	130	160	M10	4
MGT005B-D1500	3 Ph/ 380V./ 50Hz IP55, 4 Pole	0.50	0.37	1,500	19	130	160	M10	4
MGT002B-D1000	3 Ph/ 380V./ 50Hz IP55, 6 Pole	0.25	0.18	1,000	19	130	160	M10	4
MGT005B-D1000		0.50	0.37		24	165	200	M12	
MGT010B-D1000		1.00	0.75		28	165	200	M12	
MGT002A-D0600	3 Ph/ 380V./ 50Hz IP55, 10 Pole	0.25	0.18	600	24	165	200	M12	4
MGT003A-D0600		0.33	0.25						
MGT002B-D1000	3 Ph/ 380V./ 50Hz IP55, 12 Pole	0.20	0.15	500	24	165	200	M12	4

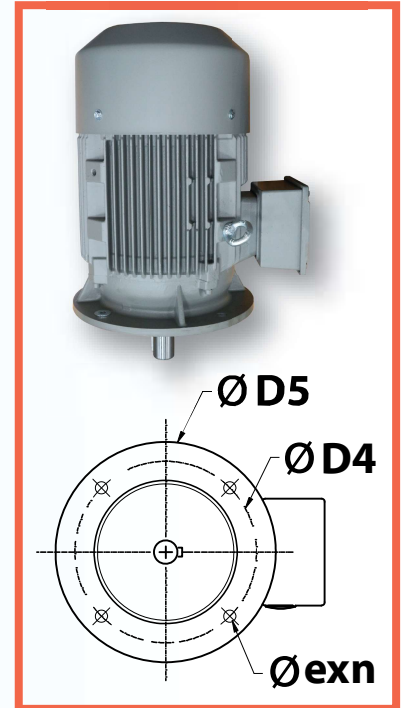

2. Geared Drive Motor 3 Phase, 380 V, 50Hz

Helical Geared motor "SEW" made in west Germany

Part Number	Description									
	Motor		Output Speed (rpm)	Flange Dimension (mm.)				Shaft Dia. (mm.) D1	S.F.	Output Torque (Nm.)
	Hp	kW		D4	D5	øe	n			
MGT001A-G0306	0.16	0.12	102	100	120	6.5	4	20	13	3.7
MGT001A-G0100			306					20	7.4	12
MGT002A-G0293	0.24	500	100	100	120	6.5	4	20	8.1	5.9
MGT002A-G0102			293					20	5	17
MGT003A-G0288	0.33	0.25	288	100	120	6.5	4	20	5.8	4.3
MGT003A-G0306	0.50	0.37	306	100	120	6.5	4	20	4.2	12
MGT003A-G0100			100	100	120	6.5	4	20	2.4	35
MGT010A-G0276	1.00	0.75	276	130	160	8.5	4	25	2.7	26
MGT010A-G0104			104	130	160	8.5	4	25	2.8	69
MGT020A-G0252	2.00	1.50	252	130	160	8.5	4	25	1.75	57
MGT030A-G0291	3.00	2.20	291	165	200	11.0	4	30	2.1	72
MGT040A-G0240	4.00	3.00	240	215	250	13.5	4	35	2.7	119
MGH055A-G0249	5.50	4.00	249	215	250	13.5	4	35	2	153
MGH075A-G0251	7.50	5.50	251	215	250	13.5	4	35	1.5	210
MGH100A-G0239	10.00	7.50	239	265	300	13.5	4	40	1.8	300
MGH150A-G0225	12.25	9.20	225	300	350	17.5	4	50	2.6	390
MGH122A-G0225	15.00	11.00	225	300	350	17.5	4	50	2.2	465
MGH200A-G0229	20.00	15.00	229	300	350	17.5	4	50	1.65	625

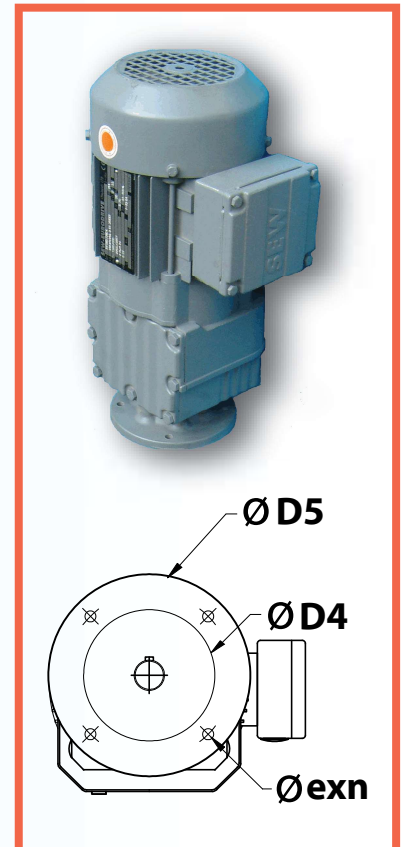

Geared Drive Agitator

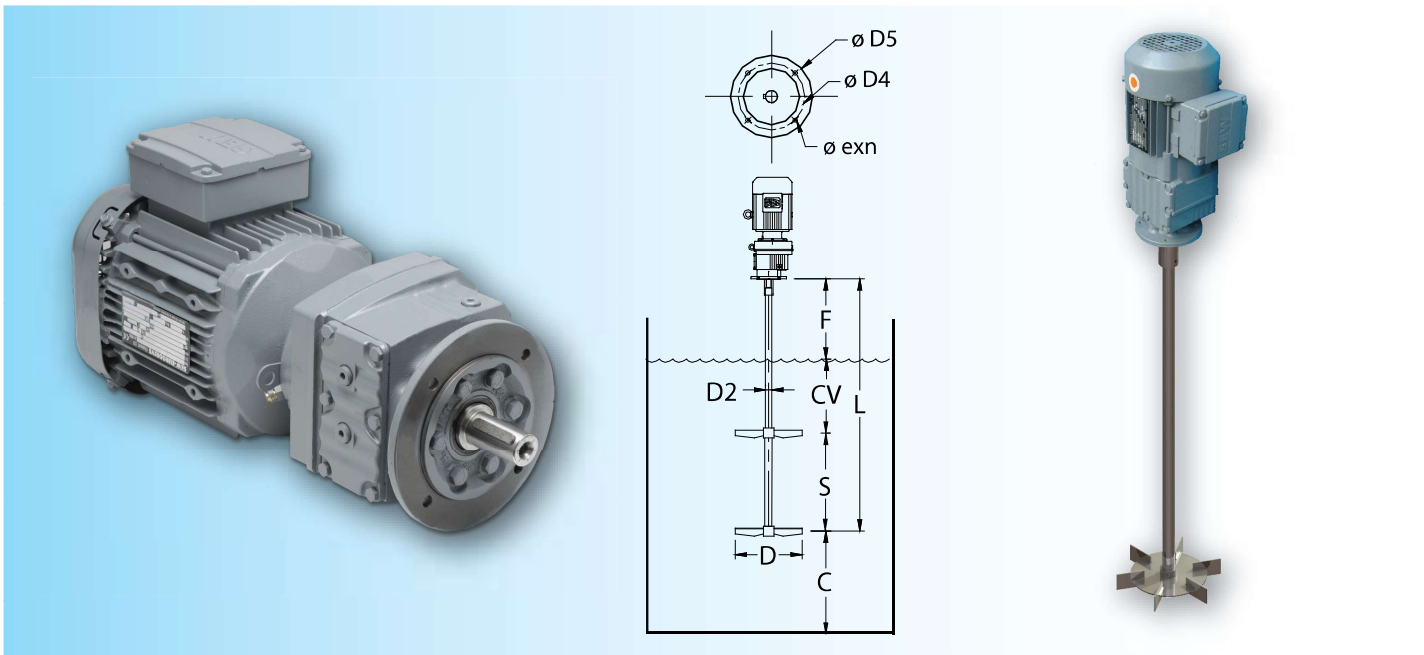

200-300 rpm, 380 V, 3 Phase., 50 Hz, IP55

Geared Motor							Coupling	Shaft Dimension (mm.)						Impeller		Maximum Agitation capacity (Ltr.)	
Power		Speed (rpm)	Flange dimension (mm.)					D2	F	S	CV	C	L	Type/ no. of stage	Diameter (mm) D		
kW	Hp		D4	D5	e	n											
0.16	0.12	306	100	120	6.5	4	C-1 20-19	-	-	550	70	450	A1-2/1	150	100		
								-	-	650	70	550			200		
								-	-	850	170	750			300		
0.25	0.18	293	100	120	6.5	4	C-4 20-19	-	-	850	110	750	A2-3/1	200	500		
0.05	0.37	276	130	160	8.5	4	C-4 25-25	-	-	1250	230	1200	A2-3/1	250	1,000		
0.75	0.55	276						25	-	-	1200	170			1200	300	1,500
1	0.75	287						-	-	-	1300	440			1300	300	2,000
1.5	1.1	291	165	200	11	4	C-4 30-32	32	-	-	1365	340	1650	A2-2/2	300	2,500	
2	1.5	255	-	-	-	4	Skirt	38	-	1500	1500	450	2000	A2-2/2	300	4,000	
3	2.2	214						50	-	700	1800	330	2500			400	6,000
3	2.2	254						50	-	600	1700	530	2300			370	6,000
4	3	218	-	-	-	4	Skirt	63	-	650	2200	830	2850	A2-2/2	450	10,000	

100 rpm, 380 V, 3 Phase., 50 Hz, IP55

Geared Motor							Coupling	Shaft Dimension (mm.)						Impeller		Maximum Agitation capacity (Ltr.)	
Power		Speed (rpm)	Flange dimension (mm.)					D2	F	S	CV	C	L	Type/ No. of Stage	Diameter (mm) D		
Hp	kW		D4	D5	e	n											
0.16	0.12	100	100	120	6.5	4	C-1 20-19	19	-	-	550	70	450	A1-2/1	200	100	
									-	-	650	70	550			200	
									-	-	850	170	750			250	300
0.25	0.18	102	100	120	6.5	4	C-4 20-19	19	-	-	1200	1277	1200	A1-4/1	350	1,000	
0.33	0.25	100							-	-	1200	1167	1200			450	1,500
0.5	0.37	104							135	160	8.5	C-4 25-25	25			-	-
1	0.75	114	165	200	11	C-4 30-32	32	-	-	700	1400	350	2100	450	4,000		
1.5	1.1	112						600	1800	430	2400	550	6,000				
2	1.5	108						250	300	14	Skirt	45	-	900	2300	480	3200

Direct Drive Agitator

Specification

- shaft, impeller and coupling are available in SUS304 or SS316 material
- output shaft of agitator motor is made from S45C steel or higher strength upon request
- over-sized output shaft and bearing get more stiffness with higher critical speed than the standard motor
- copper wire insulated is class H insulation (200 °C)

Features

- motor is constructed for mechanical simplicity with maximum structural integrity
- elimination of gear, belt and reduces periodic maintenance requirements
- reliable and dynamically balanced to virtually eliminate vibration

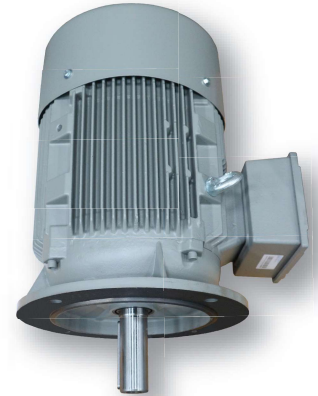

1,500 rpm, 220 V, 1 Phase., 50 Hz, IP55

Power		Speed (rpm)	Flange Dimension (mm)				Coupling	Shaft Dimension (mm)					Impeller Type/ No. of Stage	Dia (mm) D	Max. Agitation Capacity (Ltr.)
Hp	kW		D4	D5	e	n		D2	F	CV	C	L			
0.5	0.37	1,500	130	160	10	4	C-1 19-19	19	100	350	170	450	A2- 3A / 1	125	100
										450	170	550			200
										650	270	750			300
										650	210	750			500
										200	800	430			1,000
1.5	1.1		165	200	10	4	C-1 24-25	25	-	-	-	1,100	P3-3 / 1	200	1,500



1,500 rpm, 380 V, 3 Phase., 50 Hz, IP55

Power		Speed (rpm)	Flange Dimension (mm)				Coupling	Shaft Dimension (mm)					Impeller Type/ No. of Stage	Dia (mm) D	Max. Agitation Capacity (Ltr.)
Hp	kW		D4	D5	e	n		D2	F	CV	C	L			
0.5	0.37	1,500	130	160	10	4	C-1 19-19	19	100	350	170	450	A2- 3 / 1	125	100
										450	170	550			200
										650	270	750			300
										650	210	750			500
										200	800	430			1,000
1.5	1.1		165	200	10	4	C-1 24-25	25	-	-	-	1,100	P3-3 / 1	200	1,500

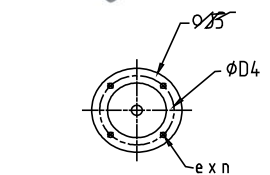

1,000 rpm, 380 V, 3 Phase., 50 Hz, IP55

Power		Speed (rpm)	Flange Dimension (mm)				Coupling	Shaft Dimension (mm)					Impeller Type/ No. of Stage	Dia (mm) D	Max. Agitation Capacity (Ltr.)
Hp	kW		D4	D5	e	n		D2	F	CV	C	L			
0.5	0.37	1,000	165	200	10	4	C-1 24-25	25	100	350	170	450	P3- 3 / 1	150	100
										450	170	550			200
										650	270	750			300
										650	210	750			500
										200	800	430			1,000
1.5	1.1		0.65	200	10	4	C-1 24-25	25	-	-	-	1,100		200	1,500

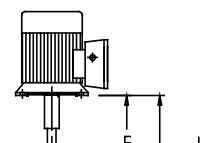

750 rpm, 380 V, 3 Phase., 50 Hz, IP55

Power		Speed (rpm)	Flange Dimension (mm)				Coupling	Shaft Dimension (mm)					Impeller Type/ No. of Stage	Dia (mm) D	Max. Agitation Capacity (Ltr.)
Hp	kW		D4	D5	e	n		D2	F	CV	C	L			
0.5	0.37	1,000	165	200	10	4	C-1 24-25	25	100	350	170	450	P3- 3 / 1	150	100
										450	170	550			200
										650	270	750			300
										650	210	750			500
										200	800	430			1,000
1	0.75		0.65	200	10	4	C-1 24-25	25	-	-	-	1,100		200	1,500

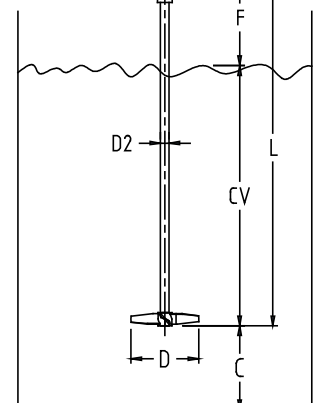

Static Mixer

A static mixer is a device, usually metal or plastic fixed to a pipe or tube. As the fluid flows through this section, it is continuously divided, reoriented, sheared and stretched by the helical right- and left-hand elements producing new interfacial elements that are subsequently recombined. Through the action of the static mixer, fluid at the center of the flow field can be directed towards the walls while material at the walls is sent to the center. This produces a distributive mixing of the fluid components in a radial direction. It can produce a homogeneous blend of dispersion in laminar, transitional or turbulent flow within a very short pipe length. It is widely used in the process industry for a large variety of mixing applications.

Mixing Principle

A "static mixer" often called an inline mixer, is a device used frequently in water treatment to create an injection point for chemicals like chlorine and soda ash into a water line. Its purpose is to create turbulence that enhances the rapid mixing of the injected chemical into the water stream. Use of the static mixer can reduce the necessary size of storage tanks following the injection point.

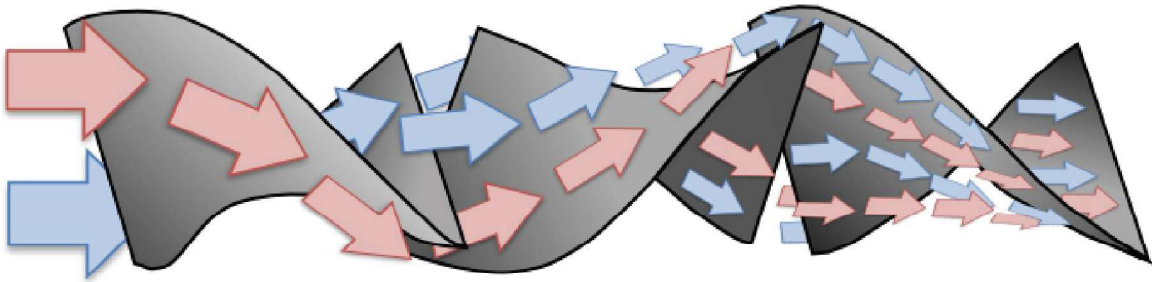

The picture above is a cutaway made to expose the inner workings of the mixer. It's a simple device. The service flow of the water is from left to right in the picture. The chemical is injected through the threaded pipe extension on the left of the mixer body. As water passes through the mixer, it is churned by the metal baffles seen in the picture and the chemical is mixed with the water.

Flow is divided equally passing each element and number of divisions increases in a geometrical progression as the number of elements increase.



Number of Elements (n)	1	2	3	4	5	6	7	8
Flow Division								
Number of Partitions (N)	2	4	8	16	32	64	128	256

The partition number $N = 2^n$, (where n is the number of elements.)

Features and Benefits

- No moving parts and no contamination
- Low capital cost and maintenance
- Easy to install as standard
- Long service life and low power requirements
- No need for tanks in most cases
- Minimal space requirement
- Improved performance of the injected chemicals.

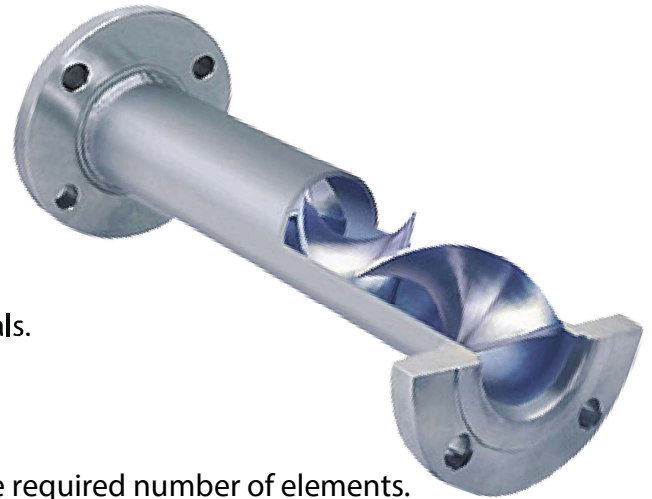

The Minimum Number of Elements

Reynolds number should be determined to specify the required number of elements. The Reynolds number can be calculated namely ;

Where:

$$Re = \frac{D_P \rho_L V_S}{\mu}$$

D_p = Pipe diameter (m)

ρ_L = Mass density of water (kg/m³)

V_s = Water Velocity (m/s)

μ = Viscosity (kg/m-sec)

Flow Regime	Reynold's Number (Re)	No. Of Elements
Laminar	<1	24
	1-10	18
	11-50	14
	51-100	12
	101-500	10
Transitional	501-1,000	8
	1,001-2,000	6
Turbulent	2,001-50,000	4
	50,001+	2

Material of Construction

- stainless steel 304 & 316L
- PP, PVC and PE
- Carbon steel

End Connection

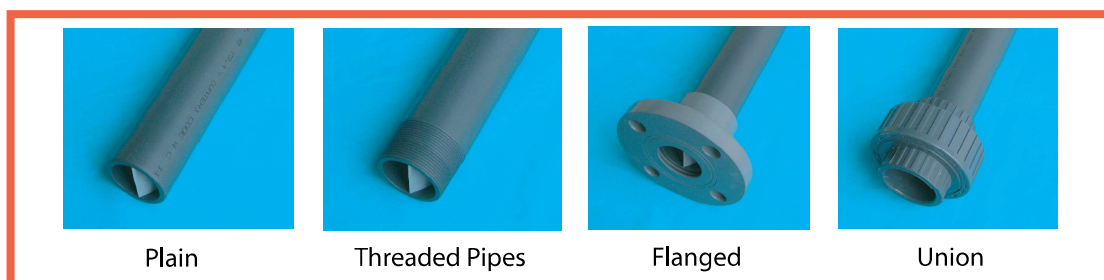

Pressure Drop Number of Element

Calculate Pressure Drop, ΔP

Where :

ΔP = Pressure Drop (kg/cm²) or (bar)

f SM = Friction Lambda static mixer (from table)

$$\Delta P = 3.061 \times 10^{-6} \times f_{NSM} \rho (\bar{u})^2 E$$

$$f_{SM} < 0.1; \mathbf{fSM} = \frac{16}{Re \cdot NO} \times 6$$

ρ = Liquid density (g/cm³)

\bar{u} = Liquid velocity (cm/s)

E = Element

PRESSURE DROP PER ELEMENT VERSUS FLOWRATE
For 1" through 12" Diameter Static Mixers

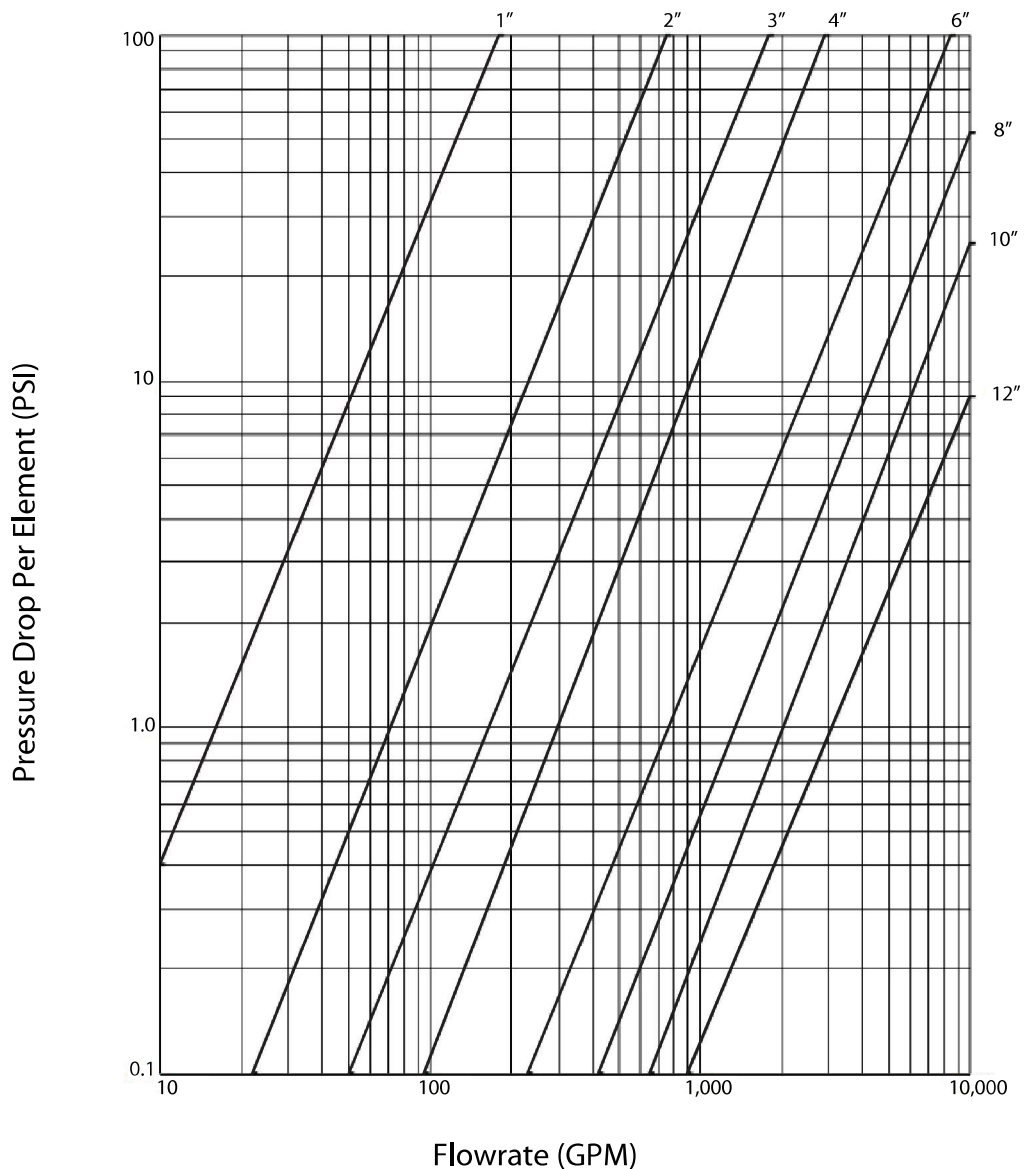

Mixer Velocity

Calculate Speed, V

$$V = \frac{Q}{A}$$

Where :

V = Velocity (m/s)

Q = Flow rate (m³/hr)

A = Area (m²)

FRICION FACTORS FOR CLEAN COMMERCIAL STEEL AND WROUGHT IRON PIPE

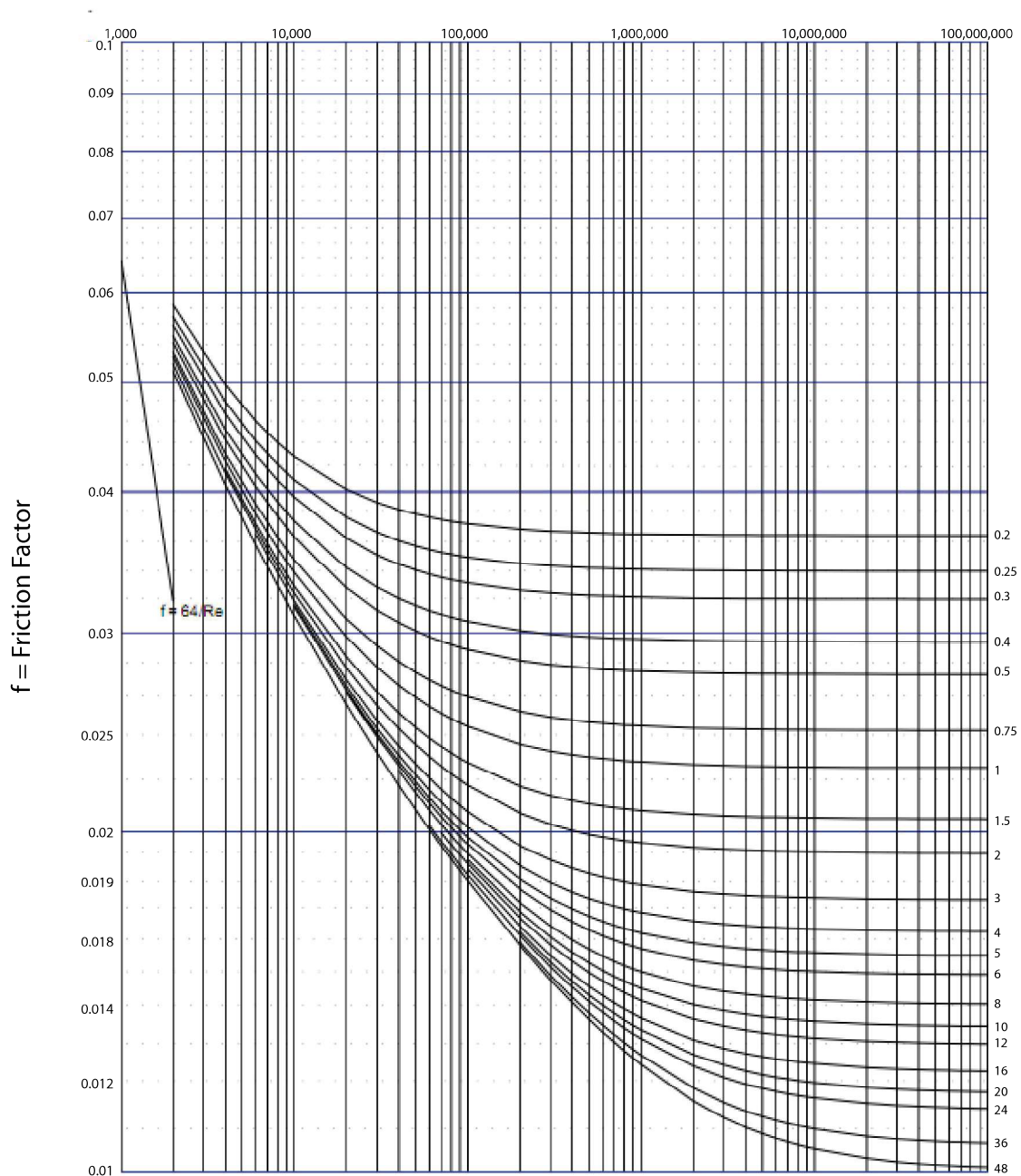

Re = Reynold's Number

Viscosity and Density of Liquids

1. μ = Dynamic Viscosity (N-s/m²)
2. ν = Kinetic Viscosity (m²/s)

$$\nu = \frac{\mu}{\rho}$$

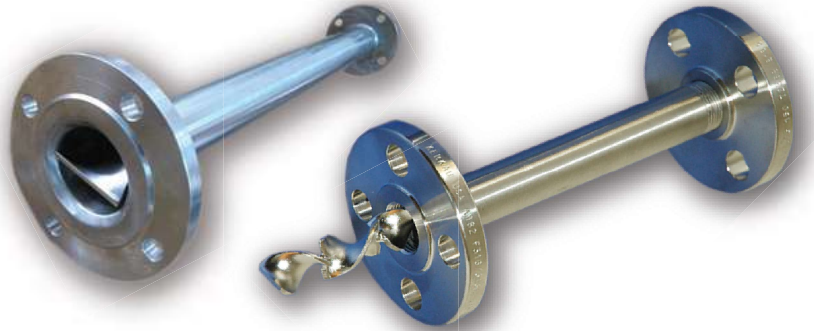

Material	T (°C)	μ (Pa.s)	ρ (kg/m ³)
Liquids	0	1.79×10^{-3}	999
Water			
Water	20	1.00×10^{-3}	998
Water	40	0.664×10^{-3}	992
Water	60	0.466×10^{-3}	983
Water	80	0.355×10^{-3}	972
Water	100	0.281×10^{-3}	958
Ethanol	20	1.20×10^{-3}	790
Glycerol	20	1.490	1261
Edible oils	20	0.05-0.2	920-950
Edible oils	100	$5-2 \times 10^{-3}$	880-900
Milk	20	2×10^{-3}	1032
Milk	70	0.7×10^{-3}	1012
Beer	0	1.3×10^{-3}	1000
Honey	25	6	1400

Water
Temperature and Dynamic Viscosity

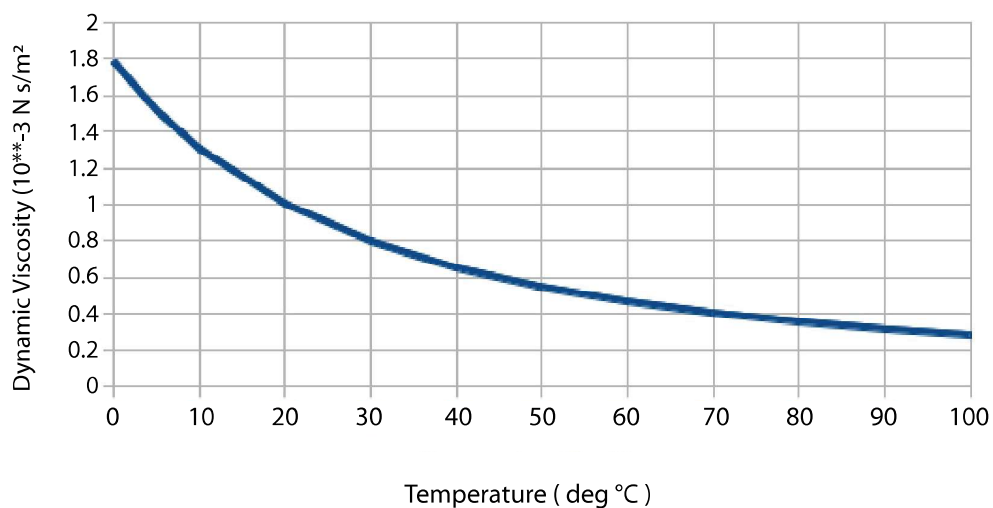

Head Loss in Static mixer

Darcy –Weisbach Equation

Where :

$$h_f = f \frac{Lv^2}{D2g}$$

f = coefficient of friction (Darcy – Weisbsch)

L = length of static mixer (m)

D = diameter of pipe (m)

V = velocity in the pipe (m/s)

G = acceleration due to gravity (9.81 m/s²)

For smooth pipe Reynolds number would give the following relationships between f and Re

$$f = 0.048(R_e)^{-0.20} \quad 10^4 < R_e < 10^6$$

$$f = 0.193(R_e)^{-0.35} \quad 3 \times 10^3 < R_e < 10^4$$

The required number of elements can also be approximated via different kinds of mixing namely ;

Number of Elements	Applications
1 - 4	- Mixing of gas low viscous fluids
4 - 6	- Mixing of low viscous fluids - Homogenization of high viscous fluids - Uniformization of temperature
6 - 12	- Gas - liquid contraction - Blending of heavy oils - Alkali washing - Aeration
12 - 18	- Mixing of medium viscous fluids - Extraction / emulsification
18 - 24	- Mixing of high viscous fluids - Mixing of two component resins / adhesives
>24	- Heat exchange / reactor - Specific purposes

InLine Static Mixer

Ordering Information



UPVC

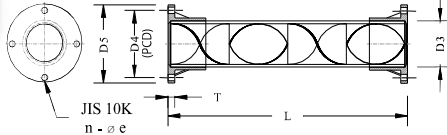

Stainless Steel

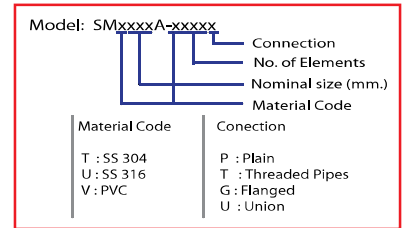
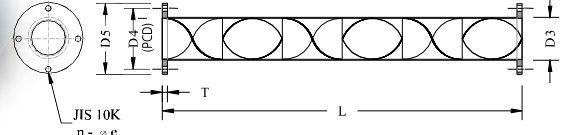

4 Elements

Part Number	Nominal Size		Approx. Dimensions (mm)						
	mm.	Inch	D3	D4	D5	L	T	n	øe
SMV020A-V004G	20	3/4	27	75	100	130	14	4	15
SMV025A-V004G	25	1	33	90	125	165	14	4	19
SMV040A-V004G	40	1-1/2	48	105	140	250	16	4	19
SMV050A-V004G	50	2	60	120	155	325	16	4	19
SMV065A-V004G	65	2-1/2	73	140	175	395	16	4	19
SMV080A-V004G	80	3	89	150	185	490	18	8	19
SMV100A-V004G	100	4	114	175	210	635	18	8	19
SMV150A-V004G	150	6	168	240	280	955	21	8	23
SMV200A-V004G	200	8	219	290	330	1,250	21	12	23

6 Elements

Part Number	Nominal Size		Approx. Dimensions (mm)						
	mm.	Inch	D3	D4	D5	L	T	n	øe
SMV020A-V006G	20	3/4	27	75	100	185	14	4	15
SMV025A-V006G	25	1	33	90	125	235	14	4	19
SMV040A-V006G	40	1-1/2	48	105	140	365	16	4	19
SMV050A-V006G	50	2	60	120	155	475	16	4	19
SMV065A-V006G	65	2-1/2	73	140	175	580	16	4	19
SMV080A-V006G	80	3	89	150	185	720	18	8	19
SMV100A-V006G	100	4	114	175	210	940	18	8	19
SMV150A-V006G	150	6	168	240	280	1,415	21	8	23
SMV200A-V006G	200	8	219	290	330	1,855	21	12	23

8 Elements

Part Number	Nominal Size		Approx. Dimensions (mm)						
	mm.	Inch	D3	D4	D5	L	T	n	øe
SMV020A-V008G	20	3/4	27	75	100	240	14	4	15
SMV025A-V008G	25	1	33	90	125	305	14	4	19
SMV040A-V008G	40	1-1/2	48	105	140	480	16	4	19
SMV050A-V008G	50	2	60	120	155	625	16	4	19
SMV065A-V008G	65	2-1/2	73	140	175	765	16	4	19
SMV080A-V008G	80	3	89	150	185	955	18	8	19
SMV100A-V008G	100	4	114	175	210	1,245	18	8	19
SMV150A-V008G	150	6	168	240	280	1,875	21	8	23
SMV200A-V008G	200	8	219	290	330	2,460	21	12	23

Submersible Mixer



Product description

Lambda Submersible mixers are mainly used for the purpose of mixing, agitating and making ring flows in the process of municipal and industrial sewage treatment and can also be used as a maintenance equipment for the landscape water environment through agitation. It can achieve the function of creating water flow, improving the quality of the water body, increasing the oxygen content in the water and effectively preventing the sedimentation of the suspended substances.

Lambda submersible mixers can also improve the growth rate of agriculture and promote higher quality of marine products. Recirculating systems can be created by this equipment designed especially for high water flow efficiency. It is a key equipment used in water treatment technology, can meet the technological requirement on the homogeneity of the two-phase solid-liquid and three-phase solid-liquid-gas flow and the fluidity in the bio-chemical processes in the flow path of the water treatment technology. The schematic drawing of the structure is shown as follows.

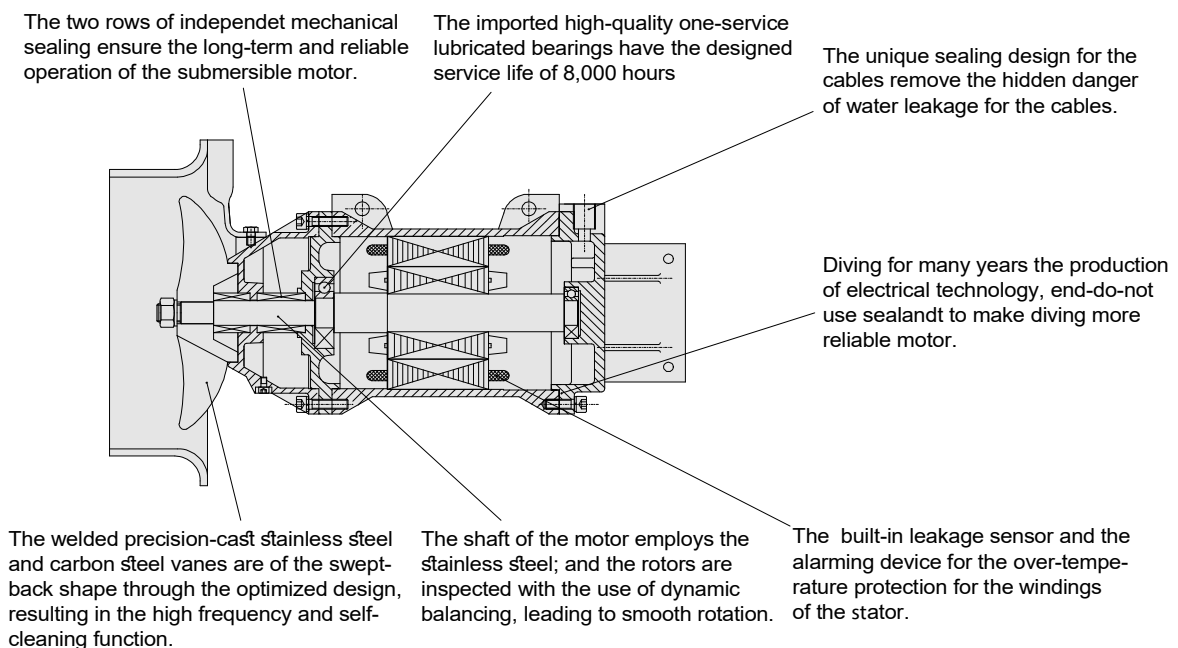

Specification

- Submersible mixer with frame and polyethylene float
 - Mixer : LSMF Series as per customers requirement
 - Float : PE with PU foam filled, float type PIN140A
 - Frame: approx. dimension 150cm(L) x 205cm(W) x 136cm(H)
- Submersible mixer with install guide system
 - Mixer : LSM Series as per customers requirement

Submersible Mixer

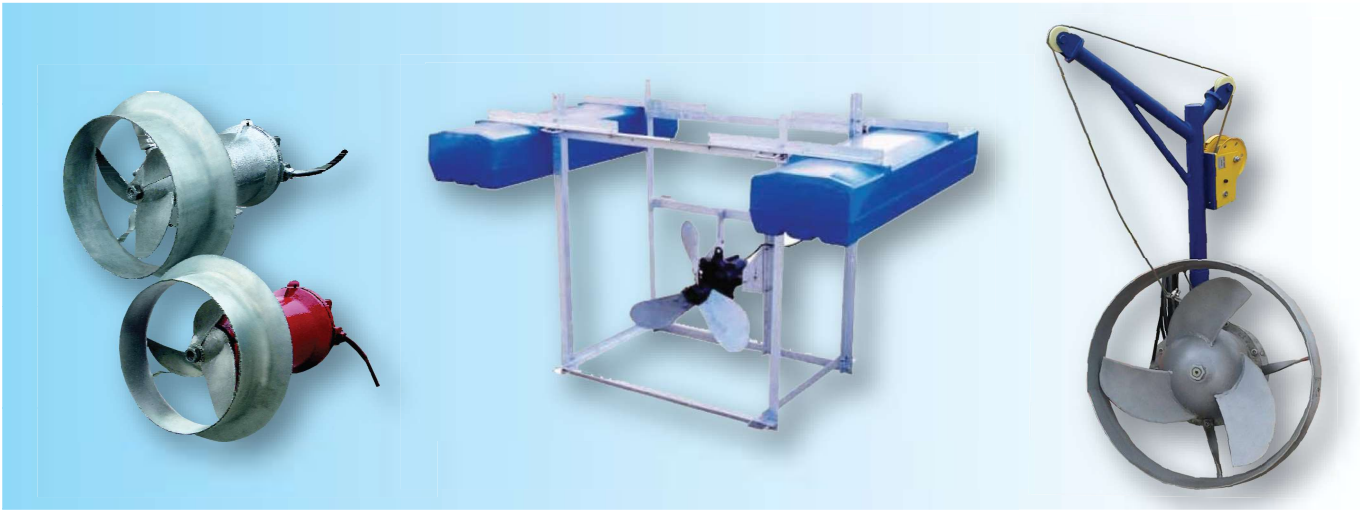

Information for Model Selection

The model selection of the submersible mixer is a rather complicated job. The correctness of the scheme selection will directly affect the normal usage of the equipment. The principle for the model is to enable the mixer to give full play to its mixing function in the appropriate volume. This standard can generally be determined with the use of the flow velocity. In line with the different technological requirement of the sewage treatment, the optimum flow velocity for the mixer model selection shall ensure the velocity range of 0.15~0.3m/s. In case of the flow velocity lower than 0.15m/s, the effect of agitation or mixing cannot be achieved. In case of the flow velocity more greater than 0.3m/s, the technological result will be affected and waste will be caused. Therefore, first of all, it is necessary to determine what kind of locations the mixer will be used in, for instance, sewage tank, slag pond or bio-chemical pond. Secondly, the parameters of the media such as content of the suspended substances, temperature, PH value as well as the shape of the pond, water depth and even the mode of installation and so on will all influence the model selection. Meanwhile, it is also necessary to consider the energy-saving factor, because this will affect the operation cost of the user in the future. Reference can be made to the diagrams of the flow field of the submersible mixer. For the purpose of obtaining the optimum mixing function under the different environments, we can supply a multiple of models of the submersible mixers to the users and provide the model selection service.

Diagrams of the Flow Field of Submersible Mixer

The flow velocity fields are located in the clear water with the boundary water flow velocity $V=0.1\text{m/s}$.

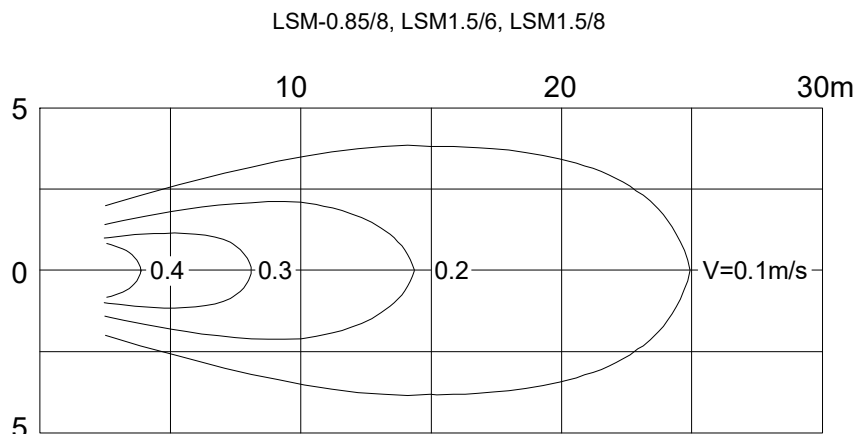

LSM-2.2/8, LSM4/6-320, LSM2.5/8, LSM3/8, LSM4/6-400

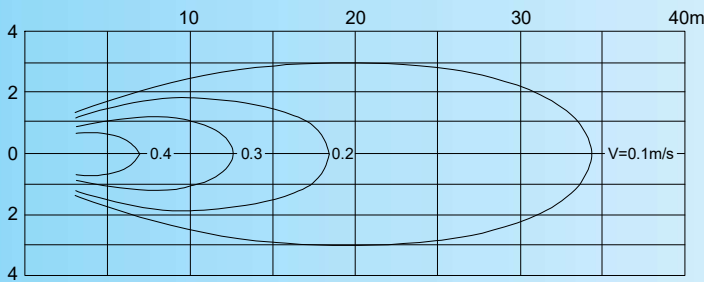

LSM-4/12, LSM5/12

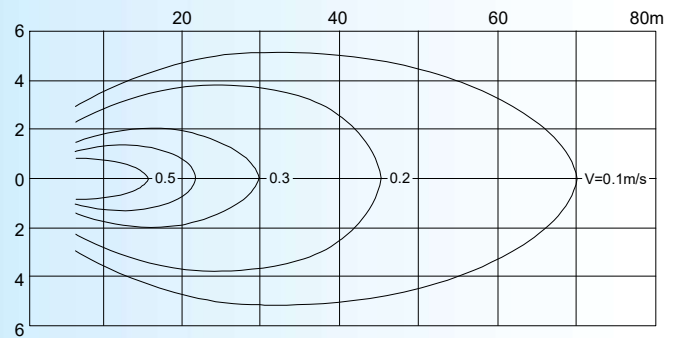

LSM-7.5/12, LSM10/12

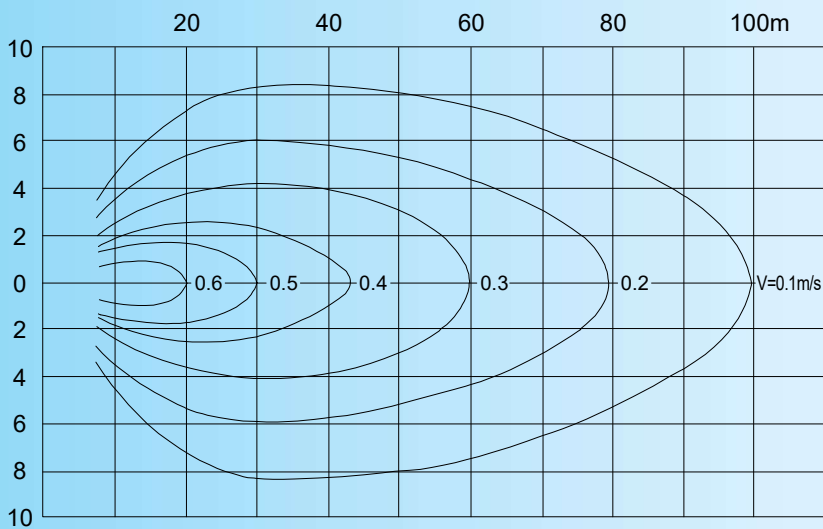

Installation Modes and Dimensions

The submersible mixers can be installed in a multiple of modes. Here are four generally accepted modes of installation for selection with reference made to the following table.

Model	a	D	b	L	h1min	h2min	Installation System
LSM-0.85	Ø48	360	330	630	500	110	I-1, I-2
LSM-1.5/6	Ø48	360	330	630	500	110	I-1, I-2
LSM-2.2/8	Ø70	460	320	970	800	150	II
LSM-4/6	Ø70	460	320	970	800	150	II
LSM-1.5/8	Ø70	530	320	960	500	200	II
LSM-2.5/8	Ø70	530	320	960	500	200	II
LSM-3/8	Ø70	530	320	1010	800	200	II
LSM-4/6	Ø70	530	320	1010	800	300	II
LSM-4/12	Ø100	820	335	1150	1100	300	III
LSM-5/12	Ø100	620	335	1150	1100	300	III
LSM-7.5/12	Ø100	820	335	1280	1500	300	III
LSM-10/12	Ø100	820	335	1280	1500	300	III

Installation System

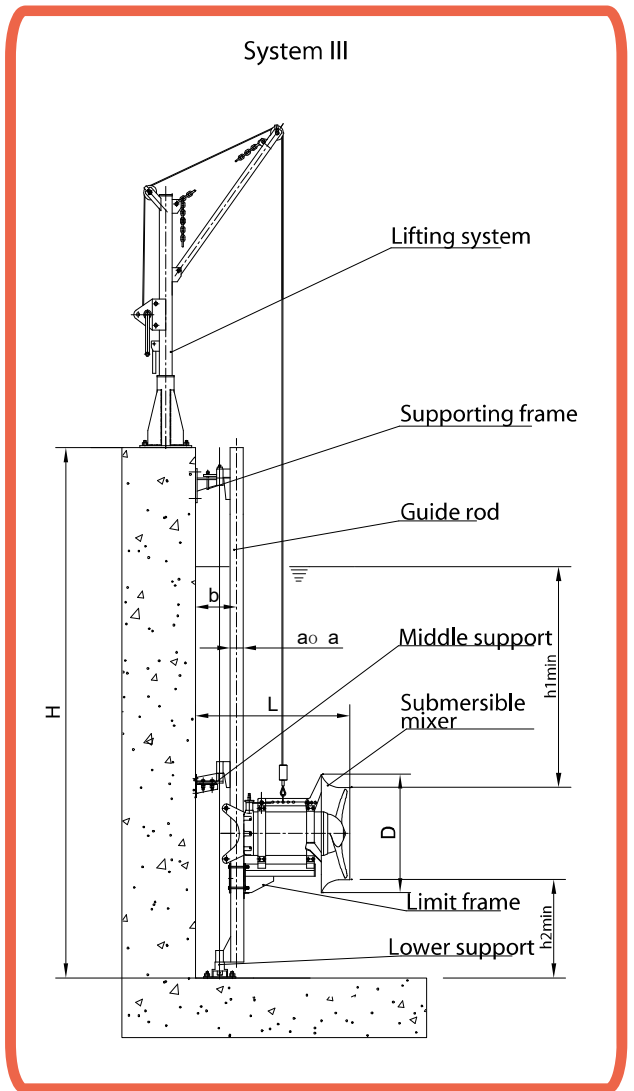
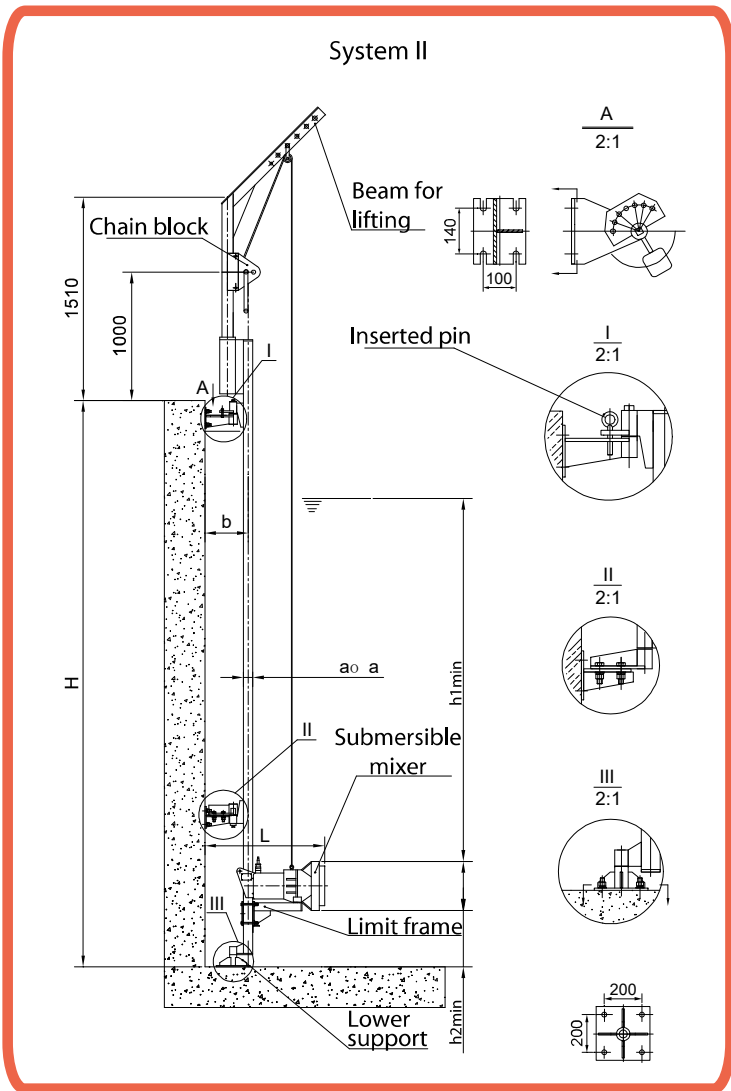
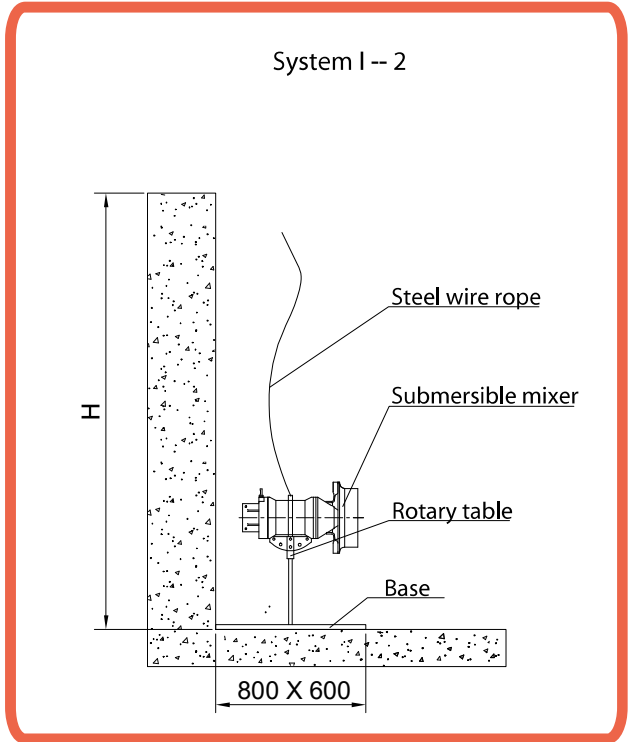
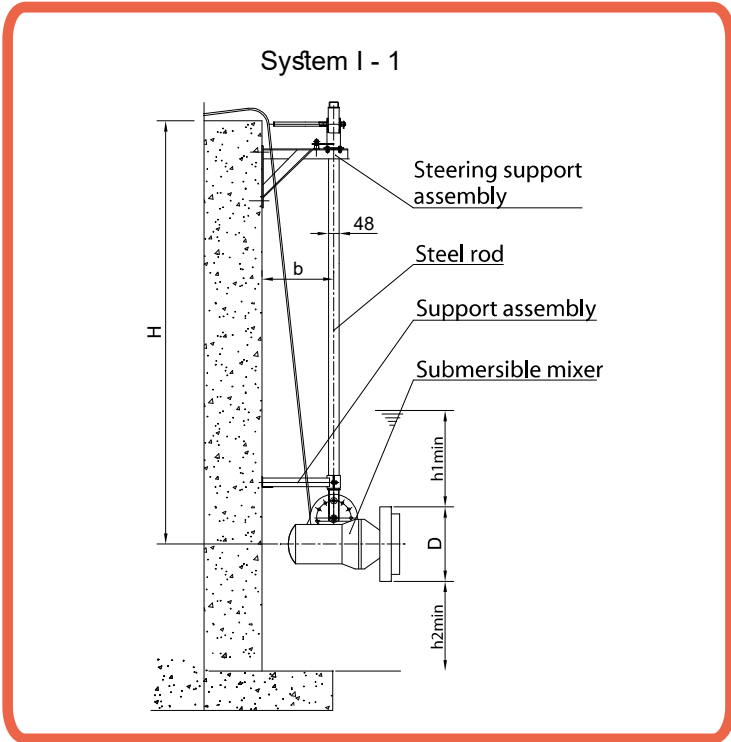

Installation System

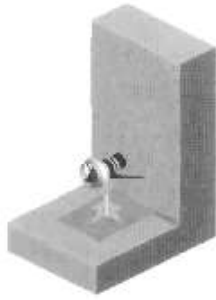

NOTE:

1. The special installation systems for the submersible mixer can facilitate the quick installation and dismantling of the submersible mixer under the conditions of no need for draining off sewage from the pond.
2. Installation System I-1 is only suitable for the pond depth $<4\text{m}$ and the mixer models of LSM0.85/8 and LSM1.5/6 and with possibility of adjusting the angles in both the horizontal and longitudinal directions. With the depth $>4\text{m}$, the installation system I-2 shall be chosen.
3. For Installation System II and III, the guide rod can rotate round the axial line of the guide along the horizontal direction with the maximum angle of rotation $\pm 6^\circ$.
4. With $H > 4\text{m}$, it is necessary to add a supporting frame between the guide rods.
5. The supporting frame and the lower support shall be fixed onto the pond and the pond bottom with the use of the expansion bolts or chemical anchors; any pre-prepared holes can be dispersed with.
6. While placing an order by customer, please supply the pond depth H and the drawing of the pond shape so as to determine the dimensions of the guide rod and the number of the support frames.
7. The installation systems may empty the material of the stainless steel or carbon steel for the selection of the corrosion resisting properties.
8. A multiple of mixers can share on lifting system.

Operating modes

The installation and positioning of the submersible mixers will produce a great impact on the effect of mixing. In order to obtain the double operating result with the half effort, it is suggested that the advice of the specialized designers shall be followed and full consideration given to the shape of the pond, position of the water inlet and outlet, the vortex resulting from the outflow from the mixer onto the structures and some other conditions. Every effort shall be made to reduce the short-circuit circulation and the occurrence of dead corners and avoid the dashing of the flow against the pond wall for lowering the flow velocity. Making reference to the diagrams of operating-modes below will help you to make a reasonable selection of the mixers and their installation modes.

Mixing and agitating series

